

2023 Associated Highway District Standards Amendment No. 1

Supplemental to Include Privately Maintained Gravel Road Standard

The following Supplemental to the 2023 Highway Standards for the Associated Highway Districts of Kootenai County (AHD Stds) is provided herein to specifically include construction guidance for Privately Maintained Gravel Roads.

Supplemental Standard Detail (SD-1B): The following Typical Road Section is intended to show the minimum dimensions for gravel road construction. Placement of materials shall be in accordance with the AHD Standards. Geometric design by a Professional Engineer shall comply with AASHTO, A Policy on Geometric Design of Highways and Streets and approved by the Director of Highways.

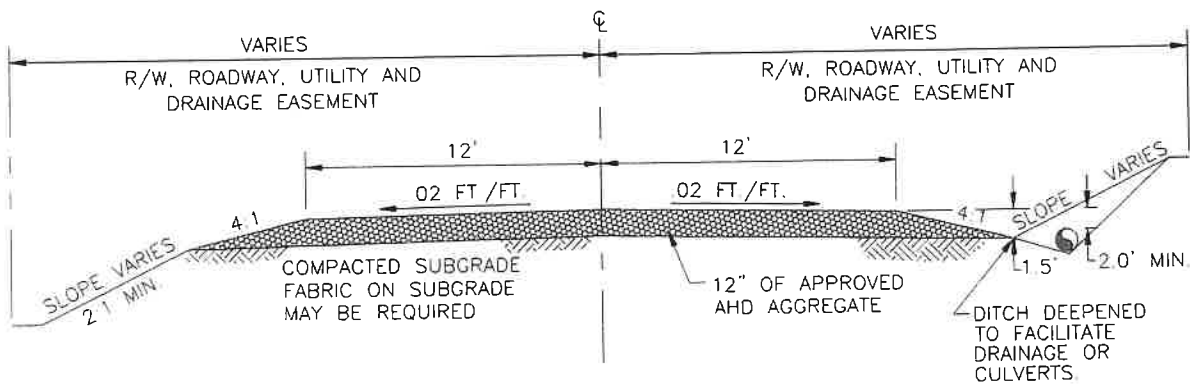

SUPPLEMENTAL SD-1B PRIVATELY MAINTAINED GRAVEL ROAD SECTION
N.T.S

Recommended for Approval:

EAST SIDE HIGHWAY DISTRICT

2/22/24
(Date)

Director Ben Weymouth, P.E.

LAKES HIGHWAY DISTRICT

2/22/24
(Date)

Director Eric Shanley, P.E.

POST FALLS HIGHWAY DISTRICT

2/22/24
(Date)

Director Michael Lenz

WORLEY HIGHWAY DISTRICT

2-22-2024
(Date)

Director Kevin Howard