

NOTE:

1. SLOPE STAKES REQUIRED ON 50' INTERVALS THROUGH TANGENTS AND 25' INTERVALS THROUGH CURVES.
2. REFERENCE STAKES REQUIRED ON 100' INTERVALS.
3. STAKING SHOWN FOR 12" BALLAST, 4" CRUSHED BASE AND 2" SURFACING.
4. AUTOMATIC SLOPE EQUIPMENT WILL REQUIRE VERIFICATION IF USED.

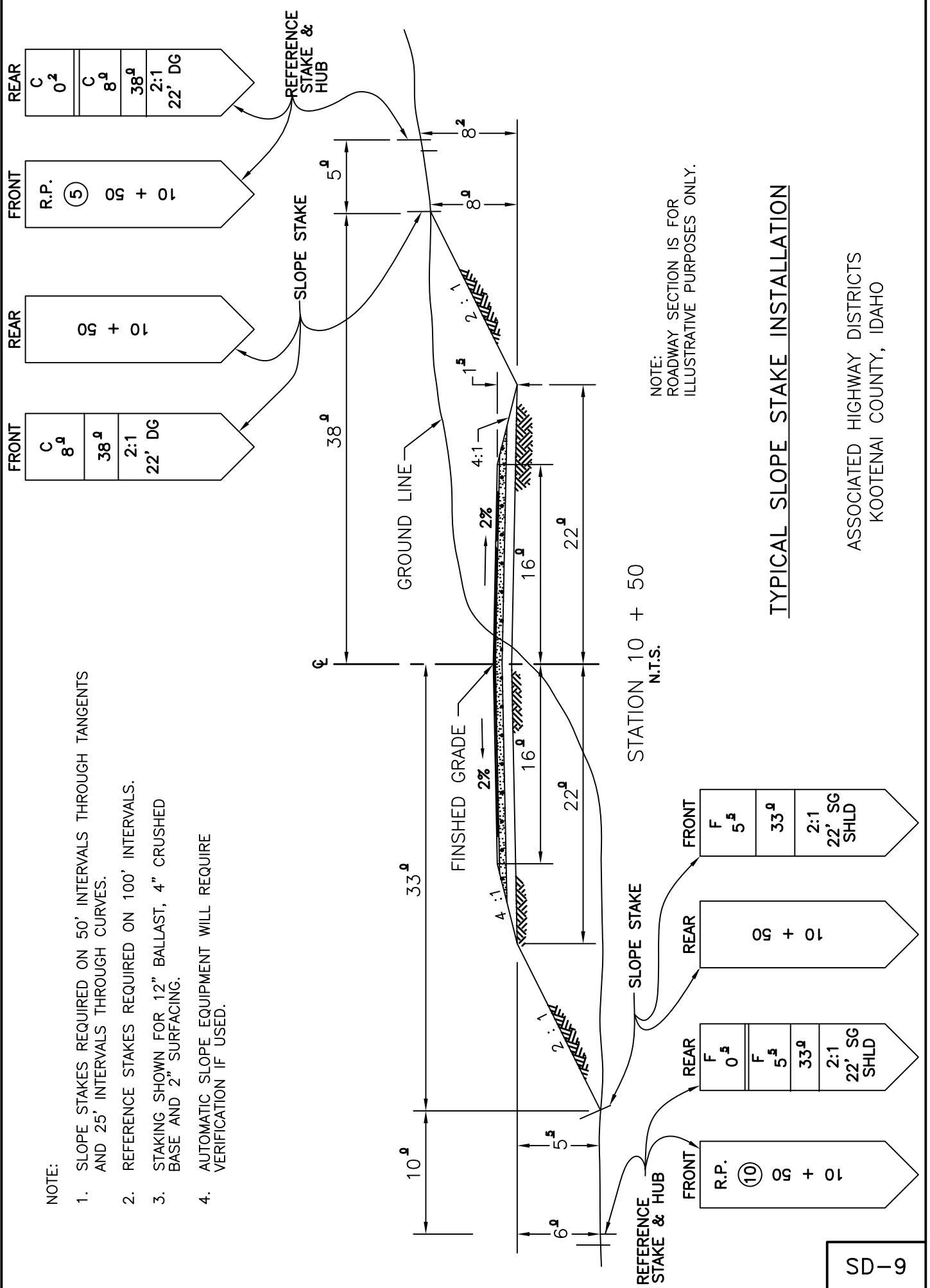

NOTE:
ROADWAY SECTION IS FOR
ILLUSTRATIVE PURPOSES ONLY.

TYPICAL SLOPE STAKE INSTALLATION

ASSOCIATED HIGHWAY DISTRICTS
KOOTENAI COUNTY, IDAHO

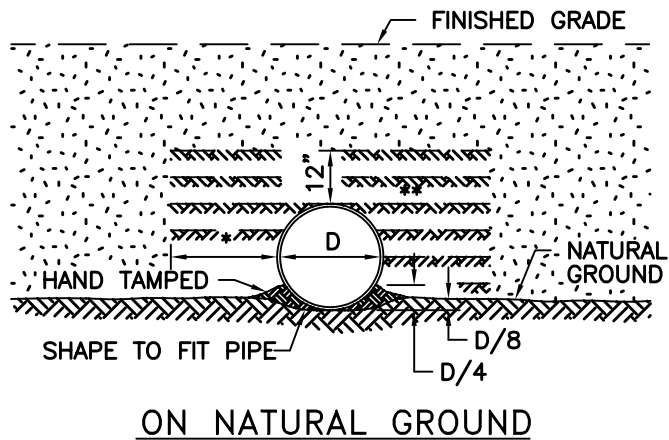
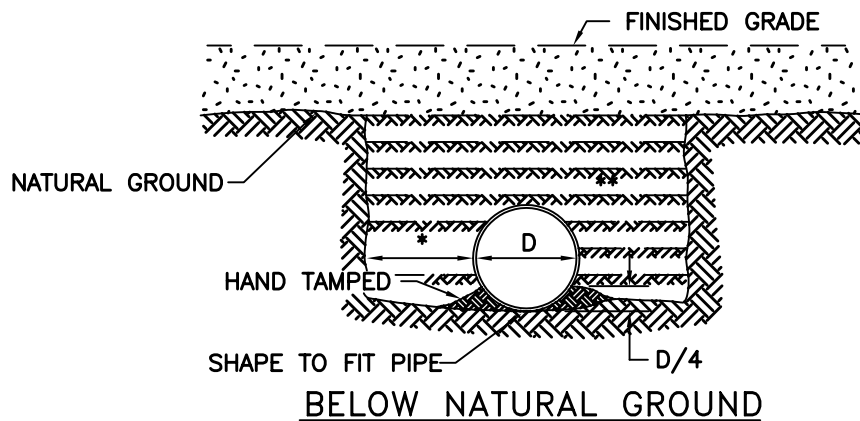
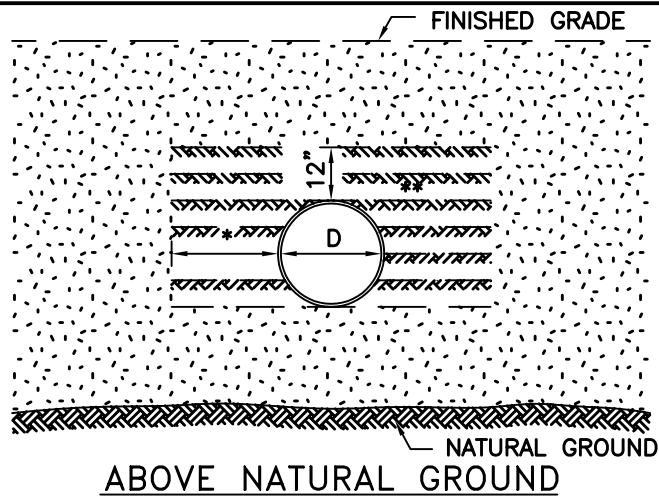

NOTE: * D OR 12" WHICHEVER IS GREATER

** MECHANICAL COMPACTED BACKFILL. PLACE IN 6" LAYERS. EACH DISTRICT MAY REQUIRE THIS MATERIAL TO BE BASE MATERIAL CONFORMING TO SUB-SECTION 404.01.

TYPICAL CULVERT INSTALLATION
N.T.S.

ASSOCIATED HIGHWAY DISTRICTS
KOOTENAI COUNTY, IDAHO

NOTE:
FOR CONTROLLED INTERSECTIONS SIGHT DISTANCE
MUST BE ADEQUATE TO PROVIDE A STOPPING SIGHT
DISTANCE IN ACCORDANCE WITH SECTION 305.01
OF THESE STANDARDS.

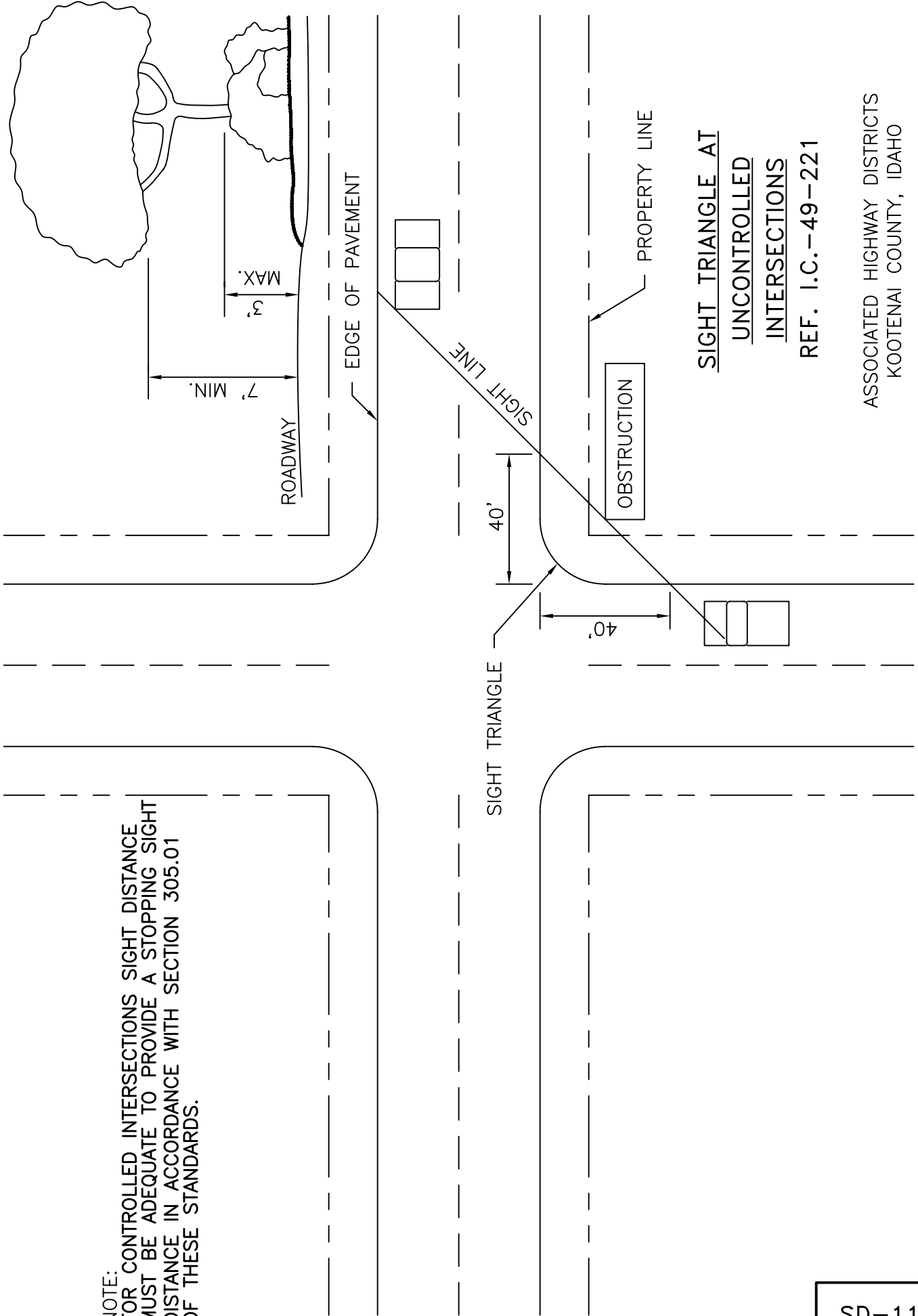

SIGHT TRIANGLE AT
UNCONTROLLED
INTERSECTIONS

REF. I.C.-49-221

ASSOCIATED HIGHWAY DISTRICTS
KOOTENAI COUNTY, IDAHO

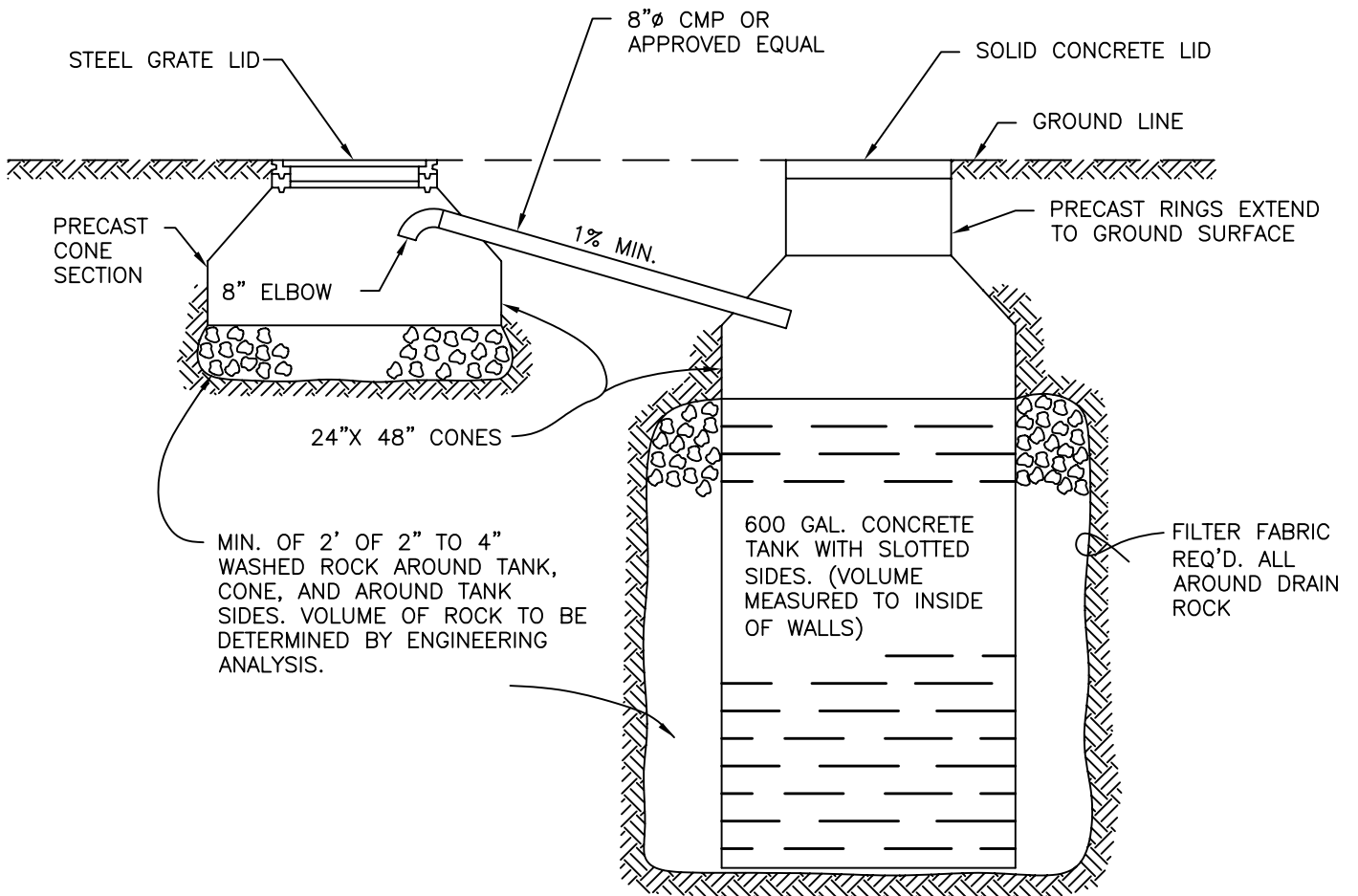

CATCH BASIN & DRYWELL INSTALLATION
N.T.S.

ASSOCIATED HIGHWAY DISTRICTS
KOOTENAI COUNTY, IDAHO

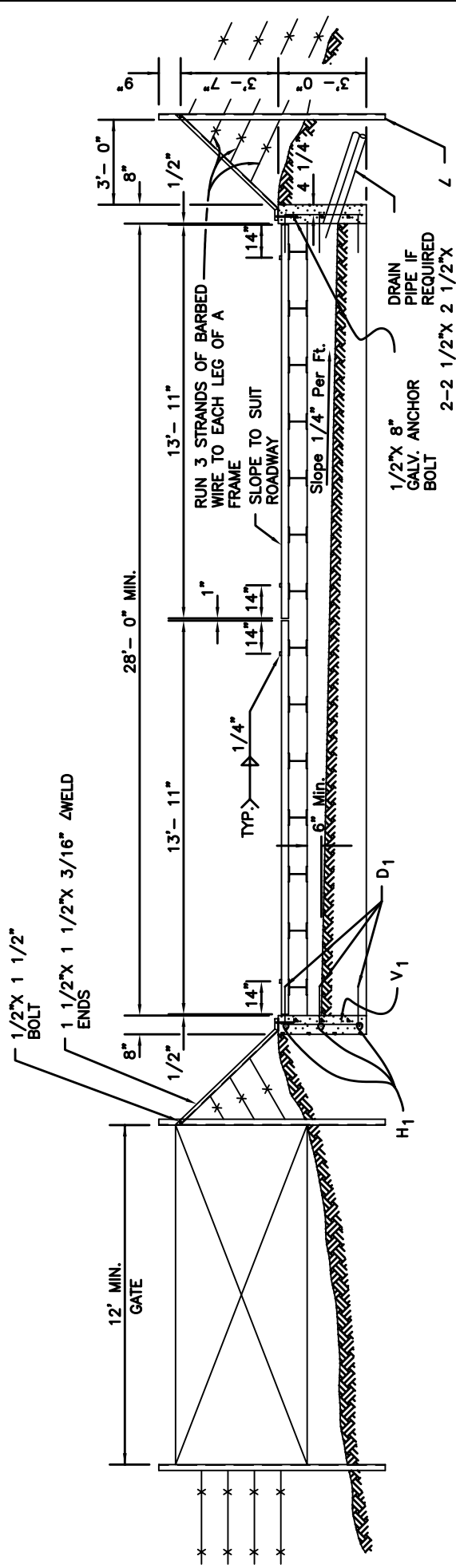

REINFORCEMENT STEEL				
MARK	LOCATION	SIZE NO.	TOTAL LENGTH	NO. REQ'D
V ₁	END WALLS	4	2'-8"	18
H ₁	END WALLS	6	9'-4"	6
D ₁	DOWELS	4	1'-4"	24

80 L.F. NO. 4 BARS AT .668 LB./FT. = 53 LB.
 56 L.F. NO. 6 BARS AT 1.502 LB./FT. = 85 LB.

CATTLE GUARD
 N.T.S.

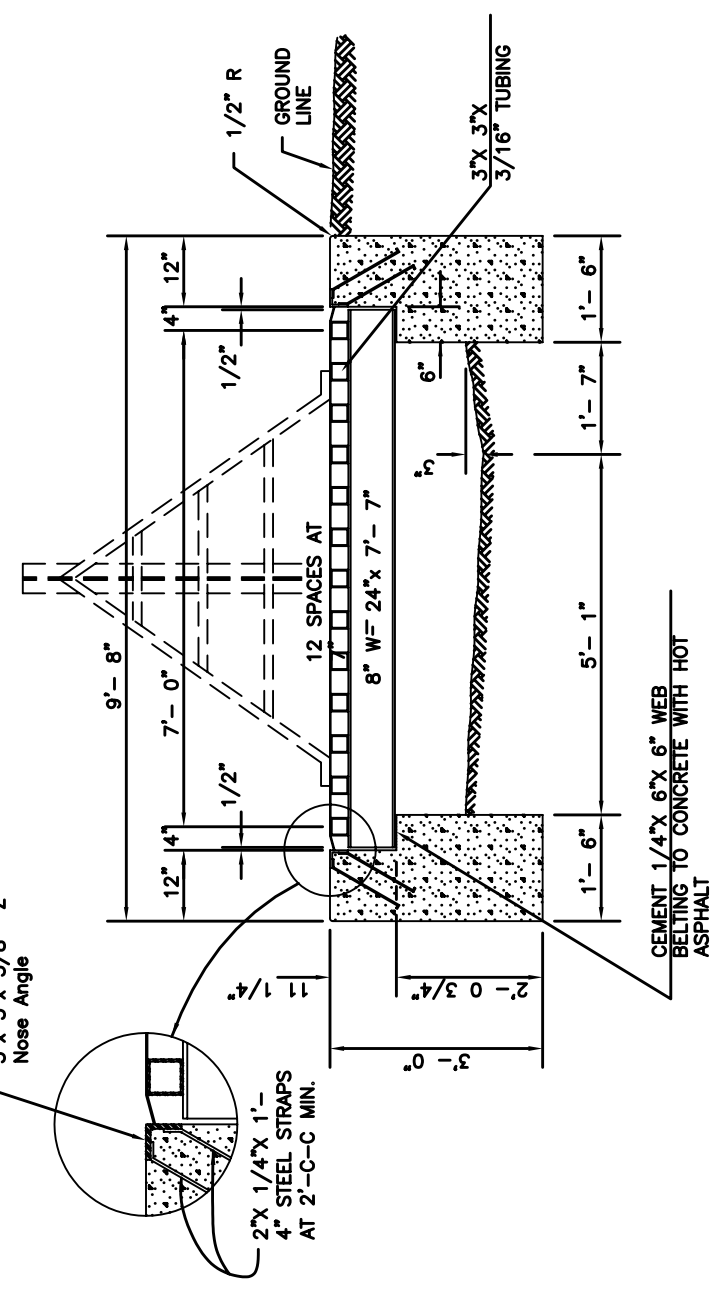

ASSOCIATED HIGHWAY DISTRICTS
 KOOTENAI COUNTY, IDAHO

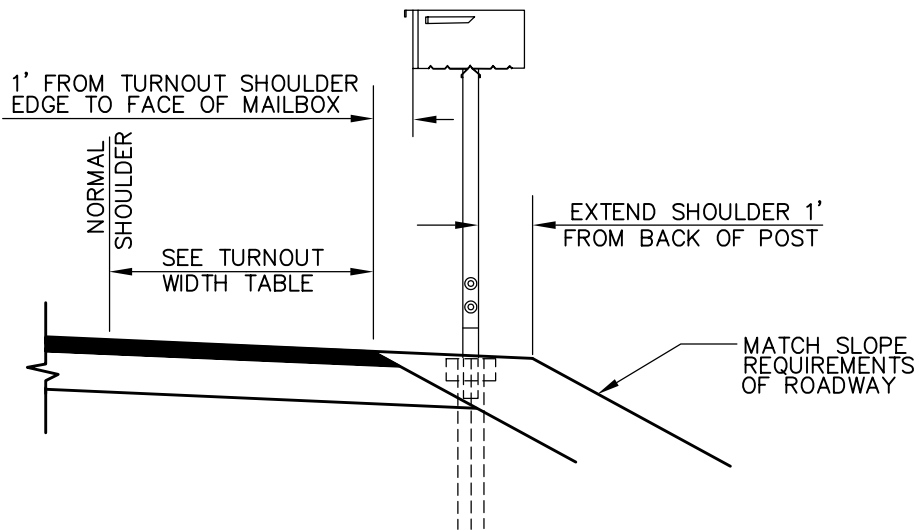

MAILBOX SLOPE TYPICAL

N.T.S.

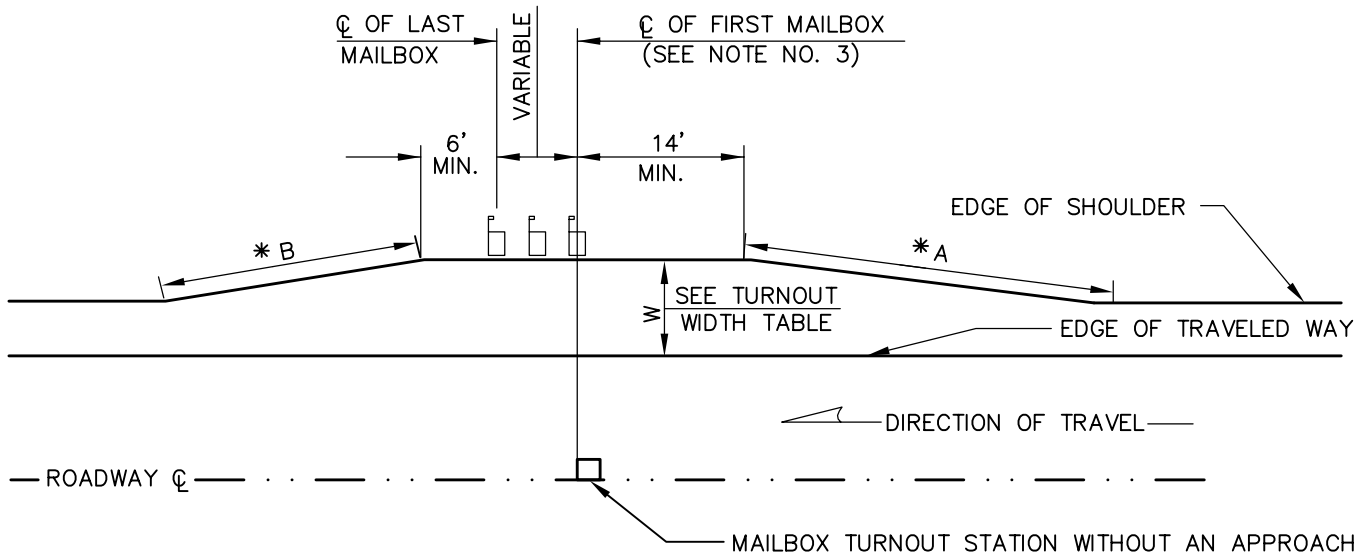

*A = 4:1 and *B = 2.5:1 TAPERS:
FOR ROADS WITH SPEEDS OF 40 MPH OR LESS, OR AN ADT OF 400 OR LESS.

*A = 20:1 and *B = 12:1 TAPERS:
FOR ROADS WITH SPEEDS GREATER THAN 40 MPH OR AN ADT GREATER THAN 400

<u>TURNOUT WIDTH TABLE</u> * (SEE NOTE NO. 2)		
SPEED/ADT	PREFERRED	MINIMUM
55/>10000	>12'	12'
55/1500-10000	12'	10'
55/100-1500	10'	8'
55/<100	8'	8'
<40/<50	8'	8'

1. WHEN USING THE TURNOUT WIDTH TABLE THE "SPEED" (MPH) IS THE MAXIMUM POSTED ROADWAY SPEED. THE "ADT" IS THE AVERAGE DAILY TRAFFIC.

2. THE BALLAST REQUIREMENTS OF MAILBOX TURNOUTS SHALL BE AS THE ADJACENT ROADWAY SECTION.

3. REFER TO THE UNITED STATES POST OFFICE STANDARDS FOR MAILBOX INSTALLATION.

MAILBOX TURNOUT DETAIL

N.T.S.

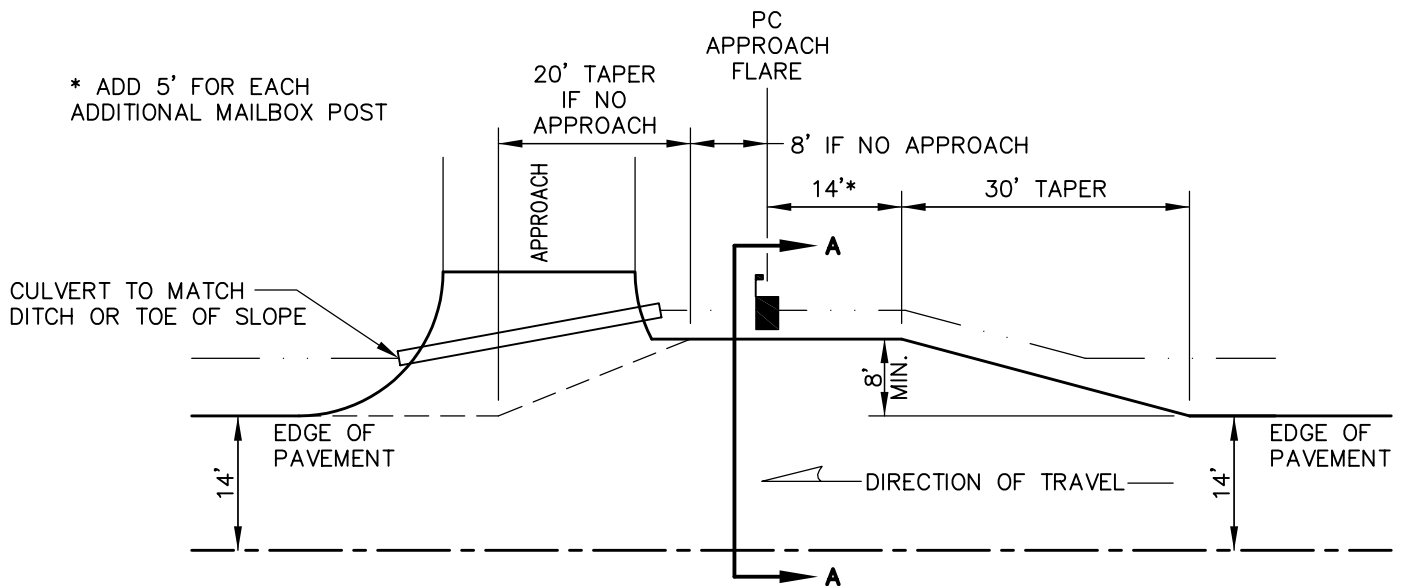
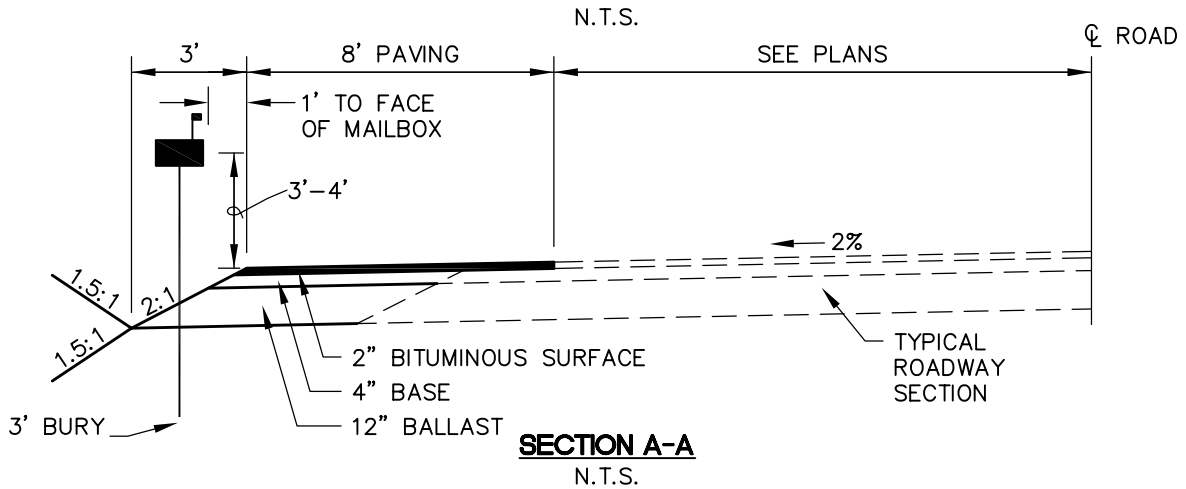
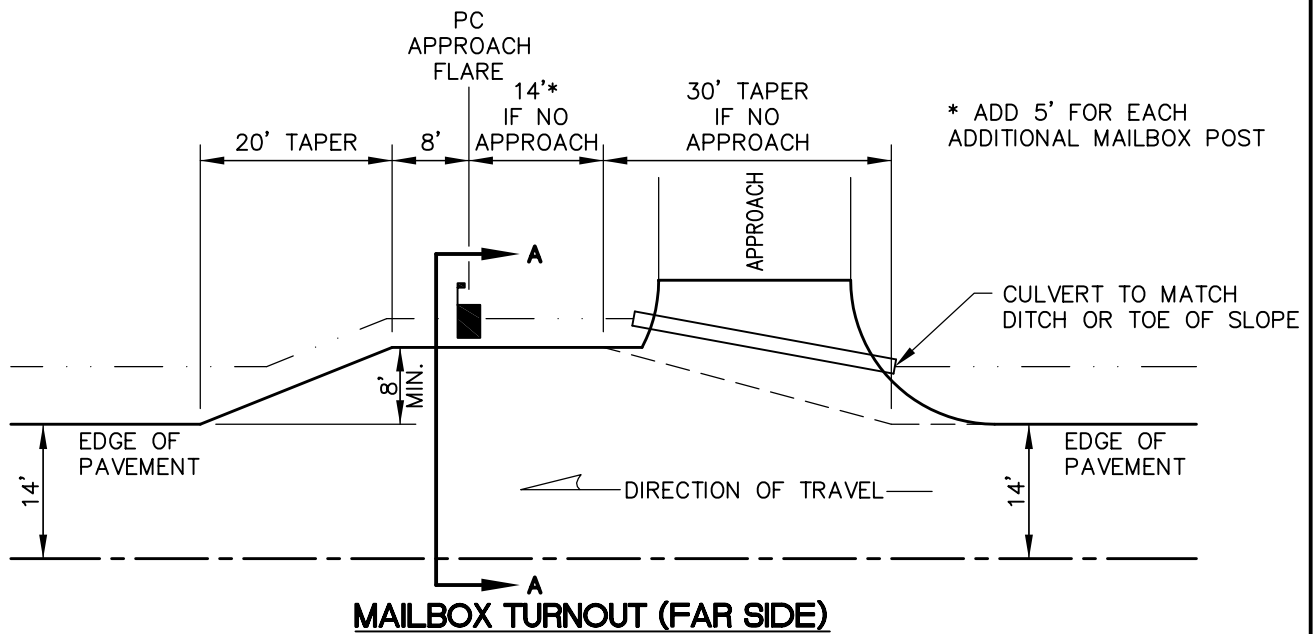

NOTES:

1. STATION SHOWN ON THE PLANS IS TO MAILBOX OR CENTER OF MULTIPLE MAILBOXES.
2. MAILBOX POST AND MOUNTINGS TO CONFORM TO IDAHO TRANSPORTATION DEPARTMENT STANDARD DRAWING H-5-A, H-5-B AND H-5-C AS APPLICABLE.
3. DRAINAGE TO BE CARRIED AROUND TURNOUTS UNLESS CULVERTS ARE INDICATED ON THE PLANS.
4. CUT AND FILL SLOPES OFF BACK OF TURNOUTS TO BE 1.5:1.
5. CONTRACTOR SHALL PROVIDE ADEQUATE ACCESS TO MAILBOXES DURING CONSTRUCTION.

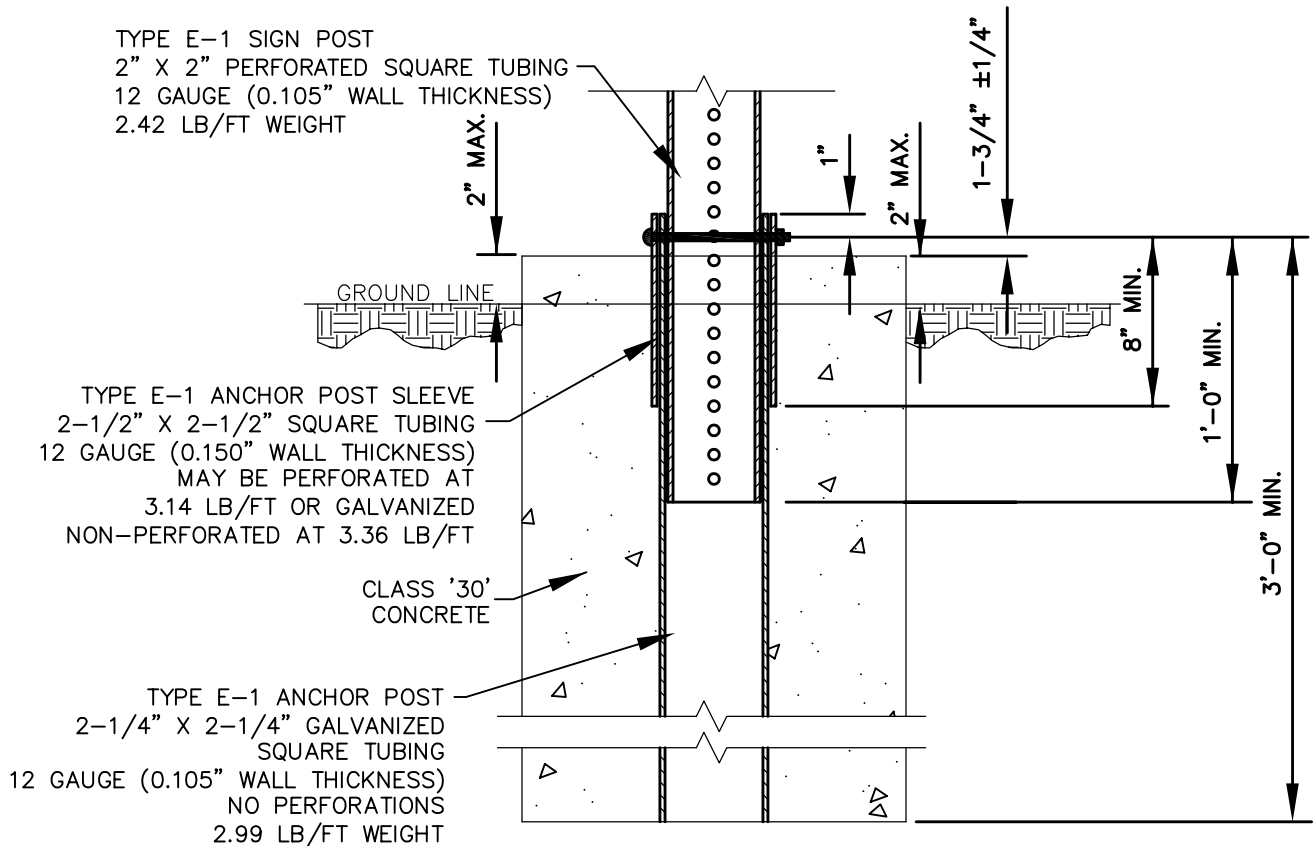
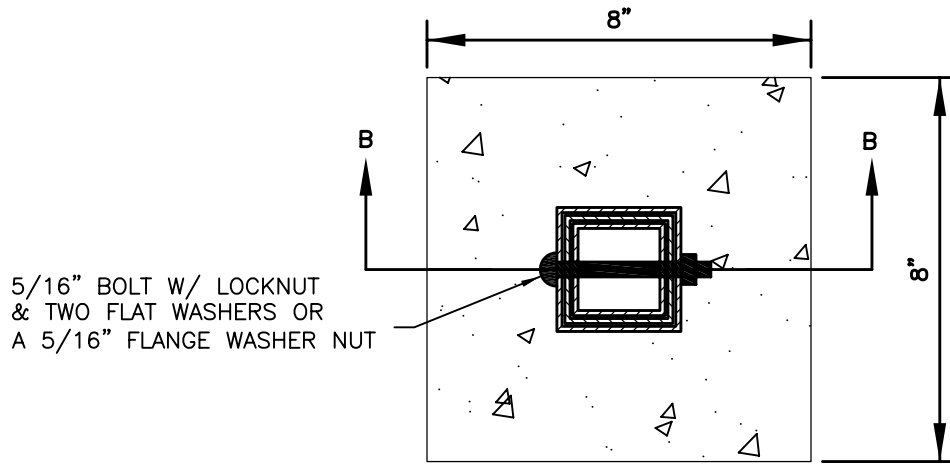

TYPE E-1 SIGN POST
SECTION B-B

NOTE:

- 1.) TYPE E-1 POST ANCHOR SLEEVES SHALL BE INSTALLED SO THAT THE HOLES WILL ALIGN AND THE TOP IS FLUSH WITH THE SIGN POST ANCHOR.
- 2.) TYPE E-1 POST ANCHOR SLEEVES SHALL BE INSTALLED SO THAT THE TRAFFIC SIGN (ONCE MOUNTED) SHALL MEET ITS INTENDED INSTALLATION REQUIREMENT.